

# TM-H5000II series

## Operator's Manual

### Using this online operator's guide

The words on the left side of this screen are bookmarks for all the topics in this guide.

Use the scroll bar next to the bookmarks to find any topic you want. Click a bookmark to instantly jump to its topic. (If you wish, you can increase the size of the bookmark area by dragging the dividing bar to the right.)

Use the scroll bar on the right side of this screen to move through the text.



Use the zoom tools to magnify or reduce the page display.



Click the Find button if you want to search for a particular term. (However, using the bookmarks is usually quicker.)

Complete online documentation for Acrobat Reader is located in the Help directory for Acrobat Reader.

[Return to main menu](#)

hybrid printer

# TM-H5000II series

Operator's Manual  
MICR Option Included

400826500

Printed in Japan

## Printer Parts and Labels

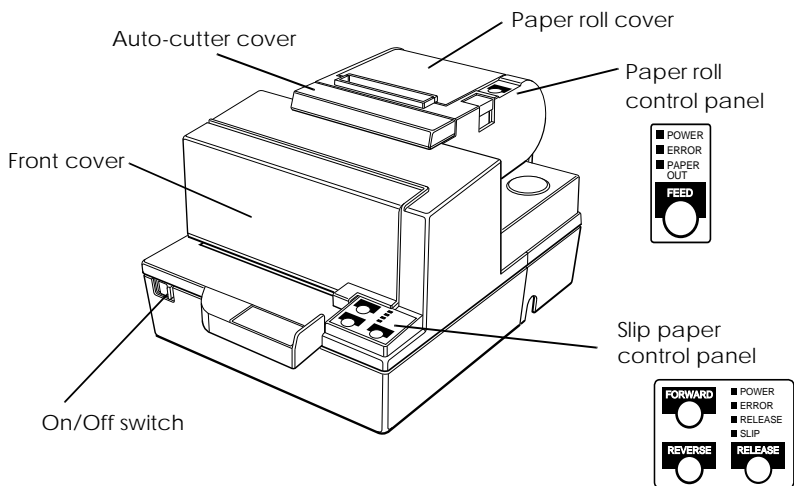

## Caution Labels



### **CAUTION:**

*Thermal head and printer head are hot.*



### **ATTENTION:**

*La tête thermique et la tête d'imprimante sont chaudes.*



### **VORSICHT:**

*Der Thermalkopf und der Druckerkopf sind heiß.*



### **CAUTION:**

*Caution labels for drawer kick-out and display module connectors.*

## Instruction Labels

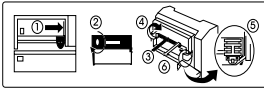

Ribbon installation  
label inside  
front cover



Label inside paper  
roll cover

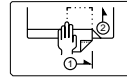

Label affixed on  
the document table



Label inside  
cutter section

## CAUTION:

Caution labels for drawer kick-out and display module connectors.

---

## ***Quick Reference***

This Quick Reference will direct you to key areas of this Operator's Manual. For a complete listing of topics, see the Contents.

***Printer Parts and Labels*** ***inside front cover***

***Ordering Paper and Ribbons*** ***page viii***

Where to order paper and ribbons.

***Setting Up the Printer*** ***page 1-1***

How to set up the printer.

***Installing and Replacing Paper*** ***page 1-10***

How to load or change the roll paper.

***Validating and Verifying Checks*** ***page 2-5***

How to validate and verify checks using the optional Magnetic Ink Character Recognition (MICR) Reader.

***Solving Problems*** ***page 3-1***

How to correct problems.

All rights reserved. No part of this publication may be reproduced, stored in a retrieval system, or transmitted in any form or by any means, electronic, mechanical, photocopying, recording, or otherwise, without the prior written permission of Seiko Epson Corporation. No patent liability is assumed with respect to the use of the information contained herein. While every precaution has been taken in the preparation of this book, Seiko Epson Corporation assumes no responsibility for errors or omissions. Neither is any liability assumed for damages resulting from the use of the information contained herein.

Neither Seiko Epson Corporation nor its affiliates shall be liable to the purchaser of this product or third parties for damages, losses, costs, or expenses incurred by purchaser or third parties as a result of: accident, misuse, or abuse of this product or unauthorized modifications, repairs, or alterations to this product, or (excluding the U.S.) failure to strictly comply with Seiko Epson Corporation's operating and maintenance instructions.

Seiko Epson Corporation shall not be liable against any damages or problems arising from the use of any options or any consumable products other than those designated as Original Epson Products or Epson Approved Products by Seiko Epson Corporation.

EPSON is a registered trademark of Seiko Epson Corporation.  
ESC/POS is a registered trademark of Seiko Epson Corporation.

**NOTICE:** The contents of this manual are subject to change without notice.

Copyright © 1997 by Seiko Epson Corporation, Nagano, Japan.

---

## **FCC CLASS A**

### ***FCC Compliance Statement***

#### ***For American Users***

This equipment has been tested and found to comply with the limits for a Class A digital device, pursuant to Part 15 of the FCC Rules. These limits are designed to provide reasonable protection against harmful interference when the equipment is operated in a commercial environment.

This equipment generates, uses, and can radiate radio frequency energy and, if not installed and used in accordance with the instruction manual, may cause harmful interference to radio communications. Operation of this equipment in a residential area is likely to cause harmful interference, in which case the user will be required to correct the interference at his own expense.

#### ***WARNING***

The connection of a non-shielded printer interface cable to this printer will invalidate the FCC Verification of this device and may cause interference levels which exceed the limits established by the FCC for this equipment.

You are cautioned that changes or modifications not expressly approved by the party responsible for compliance could void your authority to operate the equipment.

#### ***FOR CANADIAN USERS***

This Class A digital apparatus meets all requirements of the Canadian Interference-Causing Equipment Regulations.

Cet appareil numérique de la classe A respecte toutes les exigences du Règlement sur le matériel brouilleur du Canada.

#### ***GEREÄUSCHPEGEL***

Gemäß der Dritten Verordnung zum Gerätesicherheitsgesetz (Maschinenlärminformations- Verordnung-3. GSGV) ist der arbeitsplatzbezogene Geräusch-Emissionswert kleiner als 70 dB(A) (basierend auf ISO 7779).

## DECLARATION OF CONFORMITY

Product Name: Printer

Model Name: M128C

This printer conforms to the following Directives and Norms:

Directive 89/336/EEC

EN 55022 (1987 and 1994 2nd/1995) Class B

EN 50082-1 (1992)

IEC 801-2 (1991)

IEC 801-3 (1984)

IEC 801-4 (1988)

Directive 90/384/EEC

EN45501: (1992)



---

## ***EMI and Safety Standards Applied***

The following standards are applied only to the printers that are so labeled. (EMC is tested using the EPSON PS-170 power supply)

Europe: CE marking  
EN55022  
EN50082-1  
EN45501

Safety Standard: TÜV

North America: EMI: FCC Class A  
Safety standards: UL 1950-2TH-D3  
C-UL

Japan: EMI: VCCI Class 1

China (the People's Republic of China):  
Safety standards:GB4943-1995

Oceania: EMI: AS/NZS 3548 class B

---

## About This Manual

### Setting Up and Using

- ❑ **Chapter 1** contains information on unpacking the printer, setting it up, setting the DIP switches, and adjusting the paper near end sensor.
- ❑ **Chapter 2** contains information on using the printer.
- ❑ **Chapter 3** contains troubleshooting information.

### Reference

- ❑ **Chapter 4** contains specifications
- ❑ **Appendix A** tells how to change the DIP switch and paper near end settings, and **Appendix B** lists the EPSON Sales Subsidiaries and their addresses.

### Warnings, Cautions, and Notes

#### **WARNING:**

*Warnings must be followed carefully to avoid serious bodily injury.*

#### **CAUTION:**

*Cautions must be observed to avoid minor injury to yourself or damage to your equipment.*

#### **Note:**

*Notes have important information and useful tips on the operation of your printer.*

---

# ***Introduction***

---

## ***Features***

The TM-H5000II and TM-H5000IIP are high-quality POS printers that can print on slip and receipt paper (paper roll). The printers have the following features:

### ***Slip Section***

- ❑ Wide slip paper capability (maximum characters per line: 88 with 7 × 9 font).
- ❑ Copy printing is possible.
- ❑ High throughput using bidirectional, minimum distance printing.
- ❑ Optional Magnetic Ink Character Recognition (MICR) reader that enables the printer to perform consecutive reading and processing of MICR characters and printing endorsements.

### ***Receipt Section***

- ❑ High speed printing with collective printing.
- ❑ The standard auto-cutter provides easy user operation.
- ❑ Ladder bar code printing is possible by using a bar code command.
- ❑ New paper handling enables easy paper roll loading.

### ***Both Receipt and Slip***

- ❑ Standard EPSON customer display series connector (DM-D102-012/DM-D203-012) (Available only for the serial interface model).
- ❑ Selectable receive buffer size (45 bytes or 4K bytes).
- ❑ Command protocol based on the ECS/POS® standard.
- ❑ Automatic Status Back (ASB) function that automatically transmits changes in the printer status.
- ❑ Available non-volatile bit image buffer size (384K bytes)

---

## *Options and Accessories*

- Direct connection display modules, DM-D102-012 and DM-D203-012  
(Available only for the serial interface model)
- EPSON power supply unit, PS-170
- EPSON ribbon cassette, ERC-31(P) / ERC-31(B)
- Front extension table, WT-5000
- MICR feed roller cleaning sheet (adhesive type)

Part name: Sheet-roller cleaning-A  
Part code: Epson 1038046

- For cleaning the MICR head, use the following cleaning sheet that is commercially available:

Supplier name: PRESAT brand (KIC)  
Part name: CHECK READER CLEANING CARD or  
equivalent

---

## *Ordering Paper and Supplies*

Thermal paper can be ordered from the supplier in your area.

### *Specified Thermal Paper: NTP080-80*

In Japan: Nakagawa Seisakujo  
2-5-21 Nishiki-Cho Warabi-Shi  
Saitama-Ken 335 Japan

Tel: (048) 444-8211  
Fax: (048) 443-6652

In U.S.A.: Nakagawa Mfg (USA) Inc.  
2305 Lincoln Avenue  
Hayward, CA 94545 USA

Tel: (510) 782-0197  
Fax: (510) 782-7124

In Europe:

Nakagawa Mfg (Europe) GmbH.  
Krützpoort 16, 47804  
Krefeld, Germany

Tel: 02151-711051  
Fax: 02151-713293

In Southeast Asia:

N.A.K. Mfg (Malaysia) SDN BHD  
Lot 19-11, Bersatu Industrial Complex,  
Jalan Satu, Kaw Per. Cheras Jaya,.  
Balakong Industrial Area, 43200 Cheras.  
Selangor Darul Ehsan, Malaysia

Tel: 03-9047896, 9047900, 9047691  
Fax: 03-9047889

### *Other Qualified Suppliers for Thermal Paper*

The following suppliers sell thermal paper that may be used if desired. Contact each company for information.

Original paper:

TF50KS-E  
**Nippon Paper Industry Co., Ltd.**  
1-12-1, Yuraku-Cho, Chiyoda-Ku  
Tokyo 100 Japan

Tel: 03-3218-8000  
Fax: 03-3216-1375

Original paper:

PD 160R  
**New Oji Paper Mfg. Co., Ltd.**  
7-5 Ginza 4-Chome Chuo-Ku  
Tokyo 104 Japan

Tel: 03-3563-4800  
Fax: 03-3563-1136

Original paper: AF50KS-E  
**Jujo Thermal Oy (Finland)**  
P.O. Box 92 FIN27501 Kauttua Finland

Tel: 38-3932900  
Fax: 38-3932419

Original paper: P350(F380)  
**Kanzaki Specialty Papers, Inc.**  
1500 Main Street  
Spring field, MA 01115 U.S.A.

Tel: (413) 736-3216  
Fax: (413) 734-5101

### *Ordering Ribbon Cassettes*

The TM-H5000II series printer uses a long-lasting ribbon cassette in the slip section. To order ribbon cassettes, contact your dealer or your local affiliate. See Appendix B for a list of EPSON subsidiaries with their addresses and telephone numbers.

## Contents

Quick Reference .....	i
Introduction .....	vii

### *Chapter 1 Setting Up the Printer*

---

Unpacking .....	1-1
Removing the protective material .....	1-2
Connecting the Cables .....	1-3
Installing or Replacing the Paper Roll .....	1-10
Installing the Ribbon Cassette .....	1-13
Using the Power Switch Cover .....	1-15
Self Test .....	1-15
Running the self test with a paper roll .....	1-15
Running the self test with slip paper .....	1-16
Adjustments and Settings .....	1-17

### *Chapter 2 Using the Printer*

---

Operating the Control Panels .....	2-1
Paper Roll Control Panel .....	2-1
Slip Control Panel .....	2-1
Indicator lights .....	2-2
Slip Paper Handling .....	2-3
Using the MICR Reader (Option) .....	2-5
Reading MICR characters on personal checks .....	2-5

### *Chapter 3 Troubleshooting*

---

Troubleshooting .....	3-1
General problems .....	3-1
Printing problems .....	3-1
Cleaning the paper roll print head .....	3-3
Paper handling problems .....	3-4
Auto cutter problems .....	3-6
Cleaning the Optional MICR Mechanism .....	3-7
Hexadecimal Dump .....	3-10

*Chapter 4 Reference Information*

---

Printing Specifications .....	4-1
Slip Paper .....	4-1
Receipt Paper .....	4-2
Ribbon Specifications .....	4-4
MICR Reader (Option) .....	4-4
Paper Specifications .....	4-5
Electrical Characteristics .....	4-9
Reliability .....	4-10
Environmental Conditions .....	4-11

*Appendix A DIP Switch and Paper Near End Settings*

---

*Appendix B EPSON Sales Subsidiaries*

---



# Chapter 1

---

## Setting Up the Printer

---

### Unpacking

Your printer box should include these items. If any items are damaged or missing, please contact your dealer for assistance.

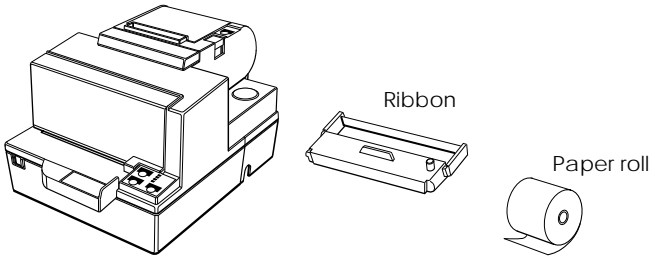

Hexagonal  
lock screws

These screws are used  
only for the serial interface  
(They are not always included.)

Switch  
cover

See the note on page 1-4 for information about the hexagonal lock screws.



**Note:**

*When you lift the printer, be sure to hold the bottom of the printer to prevent damage.*

## ***Removing the protective material***

1. Open the printer by pulling up on the tab on the front cover.

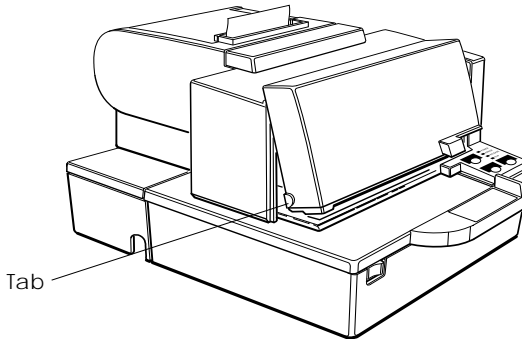

2. Remove the two dampers from the printer as shown below.

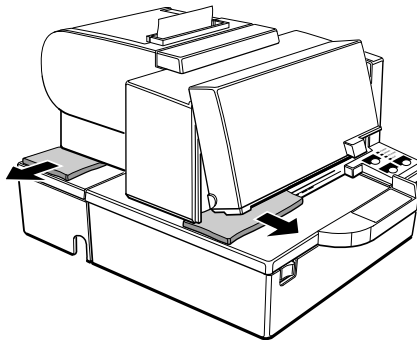

3. Store the dampers with the other packing materials and use them when transporting your printer.

---

## Connecting the Cables and Grounding the Printer

You can connect up to five cables to the printer. They all connect to the connector panel on the bottom of the printer, which is shown below:

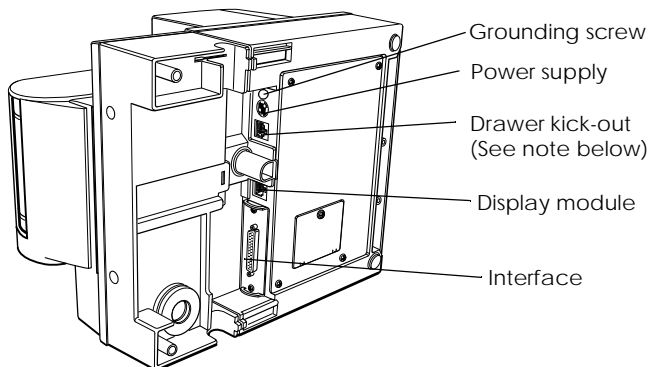

### **Note:**

*There are caution labels beside the drawer kick-out connector and the display module connector.*

*Depending on the interface installed, the interface connector on your printer may look different from the one illustrated.*

*The display module connector of the printer can be used only for the serial interface.*

Before connecting any of the cables, make sure that both the printer and the computer are turned off.

### **Connecting the computer**

You need an appropriate interface cable.

1. Plug the cable connector securely into the printer's interface connector.

2. Tighten the screws on both sides of the cable connector.

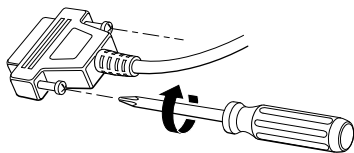

**Note:**

*Your printer has inch-type hexagonal lock screws installed. If your interface cable requires millimeter-type screws, replace the inch-type screws with the enclosed millimeter-type screws using a hex screwdriver (5 mm).*

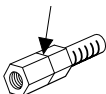

Inch screw

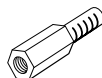

Millimeter screw

3. Attach the other end of the cable to the computer.

## Connecting the Drawer

### **WARNING:**

*Use a drawer that matches the printer specification. Using an improper drawer may damage the drawer as well as the printer.*

### **CAUTION:**

*Do not connect a telephone line to the drawer kick-out connector; otherwise the printer and the telephone line may be damaged.*

**Plug the drawer cable into the drawer kick-out connector on the bottom of the printer next to the power supply connector.**

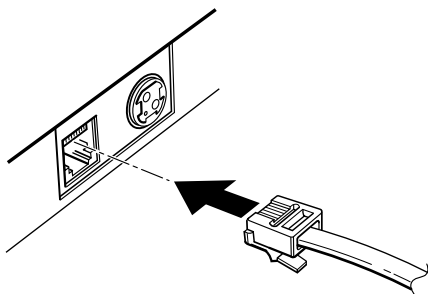

## Anschließen der Lade

### **WARNUNG:**

*Eine für den Drucker geeignete Lade verwenden. Bei Verwendung einer falschen Lade kann diese oder der Drucker beschädigt werden.*

### **ACHTUNG:**

*Kein Telefonkabel an die Schnappsteckerbuchse anschließen, da sonst der Drucker und die Telefonkabel beschädigt werden können.*

**Das Kabel der Lade an die Schnappsteckerbuchse unten am Drucker neben dem Netzanschluß anschließen.**

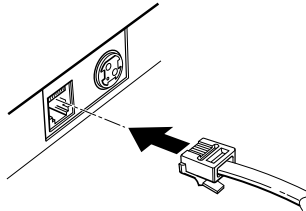

## Connecting the Display Module

The display module connector of the printer can be used only for the serial interface.

Plug the cable connector (provided with the direct connection display module) securely into the printer's display module connector until it clicks.

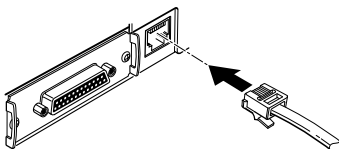

### **CAUTION:**

*Be sure not to connect this cable to the drawer kick-out connector, which is to the left of the power supply connector. Do not connect a telephone line to the display connector. If you do, the printer and the telephone line may be damaged.*

### **Notes:**

*To remove the cable, squeeze the connector and pull it out.*

## Grounding the Printer

You need a ground wire to ground your printer. Make sure that the wire is AWG 18 or equivalent.

1. Make sure that the printer is turned off.

2. Connect the ground wire to the printer using the FG screw on the bottom of the printer, as shown.

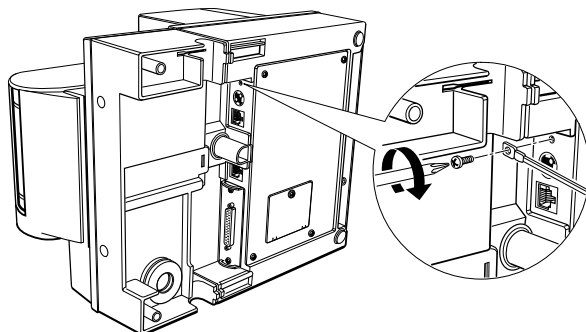

### ***Connecting the Power Supply***

Use the optional EPSON PS-170 or equivalent power supply for your printer.

### ***WARNING:***

*Make sure that you use the EPSON PS-170 power supply or equivalent. Using an incorrect power supply may cause fire or electrical shock.*



## **CAUTIONS:**

*When connecting or disconnecting the power supply from the printer, make sure that the power supply is not plugged into an electrical outlet. Otherwise you may damage the power supply or the printer.*

*If the power supply's rated voltage and your outlet's voltage do not match, contact your dealer for assistance. Do not plug in the power cord. Otherwise you may damage the power supply or the printer.*

1. Make sure that the printer's power switch is turned off, and the power supply's power cord is unplugged from the electrical outlet.
2. Check the label on the power supply to make sure that the voltage required by the power supply matches that of your electrical outlet.
3. Plug in the power supply's cable as shown below. Notice that the flat side of the plug faces down.

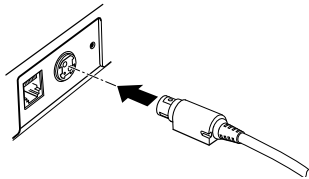

### **Note:**

*To remove the DC cable connector, make sure that the power supply's power cord is unplugged; then grasp the connector at the arrow and pull it straight out.*

---

## Installing or Replacing the Paper Roll



### Note:

Be sure to use paper rolls that meet the specifications. Do not use paper rolls that have the paper glued to the core because the printer cannot detect the paper end correctly.

1. Make sure that the printer is not receiving data; otherwise, data may be lost.
2. Open the paper roll cover by pressing the cover-open button. If the cover-open button will not open the cover, see page 3-4 in Troubleshooting.

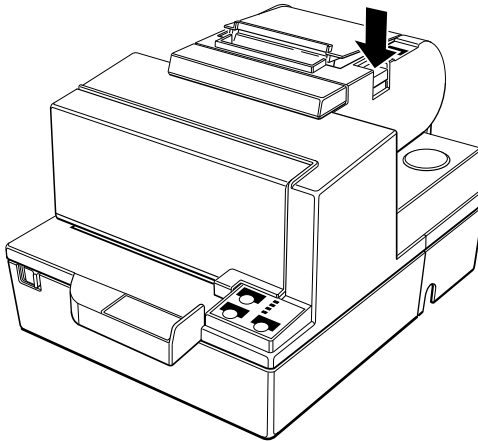

3. Remove the used paper roll core if there is one.

4. Insert the paper roll as shown.

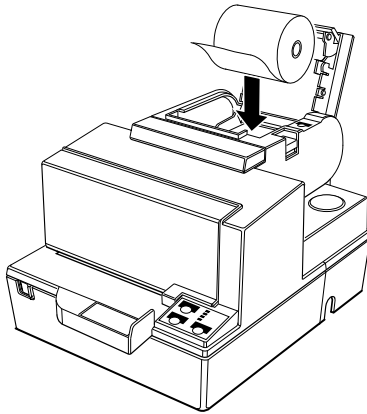

5. Be sure to note the correct direction that the paper comes off the roll.

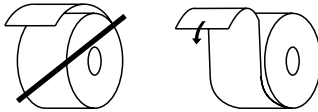

6. Pull out a small amount of paper, as shown. Then close the cover.

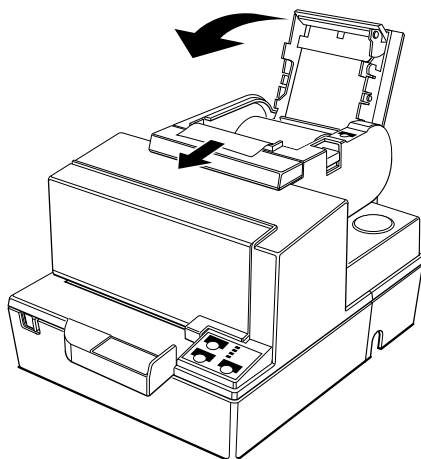

7. Tear off the paper as shown.

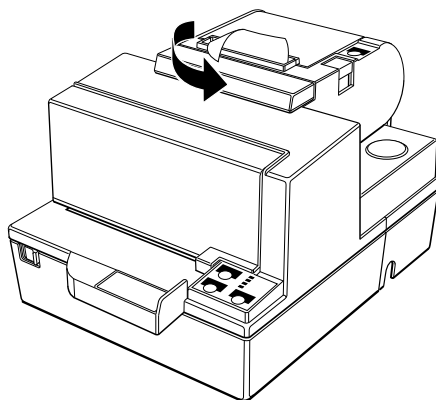

---

## Installing the Ribbon Cassette

Use the EPSON ERC-31(P) ribbon cassette for your printer.

Note the label inside this section that can assist you in replacing the ribbon.

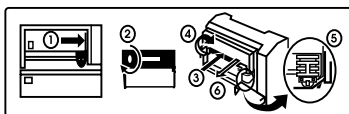

### **CAUTION:**

*Never turn the ribbon knob in the opposite direction of the arrow marked on the cassette; otherwise the ribbon cassette may be damaged.*

1. Be sure the printer is not receiving data when you replace a ribbon cassette; otherwise data may be lost.
2. Turn on the printer and open the front cover by pulling up on the tab on the left side of the cover.

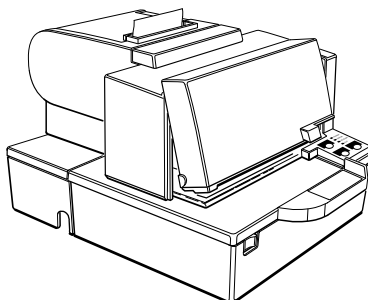

3. Make sure that the print head is on the right side.

4. If you are replacing a used ribbon, grasp the end of the tab and remove it from the printer. See the illustration in step 5 for the location of the tab.
5. Turn the ribbon knob two or three times in the direction of the arrow to take up any slack in the ribbon.

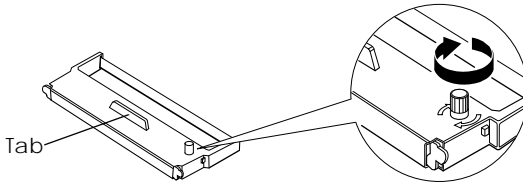

6. Insert the ribbon cassette in the printer and rotate the cassette's knob two or three more times. This is necessary to place the ribbon in the correct position.

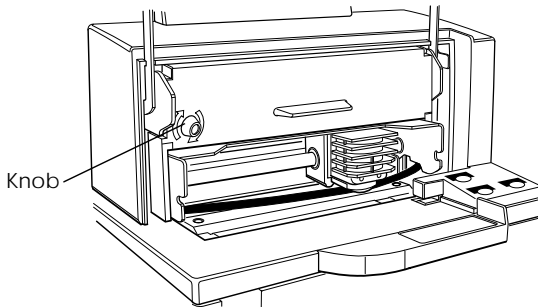

Make sure that the ribbon is installed below the print head without wrinkles or creases. (See ⑤ on the label for an illustration of where the ribbon should go.)

If the ribbon is not installed correctly, remove the cassette and repeat steps 5 and 6 above.

---

## *Using the Power Switch Cover*

### **WARNING:**

*If an accident occurs when the power switch cover is attached, unplug the power supply cord from the outlet immediately. Continued usage may lead to fire or shock.*

You can use the enclosed power switch cover to make sure that the power switch is not accidentally pressed. If you want to use this cover, install it as shown in the illustration below.

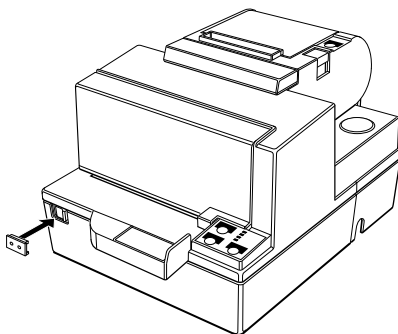

---

## *Self Test*

The self test lets you know if your printer is operating properly. It checks the control circuits, printer mechanisms, print quality, ROM version, and DIP switch settings. (It also checks the MICR reader circuits if the printer is equipped with the optional MICR reader.)

This test is independent of any other equipment or software.

You can run the self test with either paper roll or slip paper.

### *Running the self test with a paper roll*

1. Make sure the printer is turned off and the printer covers are closed properly.

2. While holding down the FEED button, turn on the printer using the switch on the front of the printer to begin the self test. The self test prints the printer settings and then prints the following, cuts the paper, and pauses. (The PAPER OUT light blinks.)

Self test printing.  
Please press the PAPER FEED button.

3. Press the FEED button to continue printing. The printer prints a pattern using the built-in character set.
4. The self test automatically ends and cuts the paper after printing the following:

\*\*\* completed \*\*\*

The printer is ready to receive data as soon as it completes the self test.



**Note:**

*If you want to pause the self test manually, press the FEED button. Press the FEED button again to continue the self test.*

### ***Running the self test with slip paper***

1. Make sure the printer is turned off and the printer cover is closed properly.
2. While holding down the REVERSE button, turn on the printer to begin the self test. (The SLIP light blinks.)
3. Feed a sheet of slip paper into the printer. The printer loads the paper automatically, prints the printer settings, and then ejects the paper.



4. Remove the paper from the printer and feed another sheet of slip paper into the printer to print characters from the character table. Continue to feed slip paper into the printer until the self test prints the following:

\*\*\*completed\*\*\*

The printer is ready to receive data as soon as it completes the self test.



**Note:**

*If you want to pause the self test manually, press the REVERSE button. Press the REVERSE button again to continue the self test.*

---

## ***Adjustments and Settings***

The TM-H5000II / H5000IIP is set up at the factory to be appropriate for almost all users. It does, however, offer some settings for users with special requirements.

It has DIP switches that allow you to change communication settings, such as handshaking and parity check, as well as print density and connection to a customer display.

The TM-H5000II /H5000IIP also has a near-end sensor for the paper in the receipt section. This can give you a warning when the paper is almost out. If you find that there is not enough paper remaining on the roll when the near-end sensor is triggered, you can change the near-end sensor setting.

See Appendix A if you need to make any of these changes.

## Chapter 2

# Using the Printer

---

## Operating the Control Panels

You can control the basic paper feeding operations of the printer with the buttons on the control panels. The indicator lights help you monitor the printer's status.

### Paper Roll Control Panel

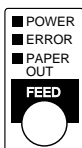

### Button

The button can be disabled by the **ESC c 5** command, but it works whenever the printer cover is open, even if it has been disabled by the **ESC c 5** command.

Press the FEED button once to advance receipt paper one line. You can also hold down the FEED button to feed receipt paper continuously.

### Slip Control Panel

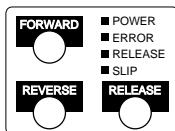

## **Buttons**

The printer and these buttons will not operate when the cover is open. Also these buttons can be disabled with the **ESC c 5** command.

### **FORWARD**

When the printer is in the slip mode (the SLIP light is on or blinking), press the FORWARD button once to advance slip paper one line. You can also hold down this button to feed slip paper continuously.

### **REVERSE**

When the printer is in the slip mode (the SLIP light is on or blinking), press the REVERSE button once to reverse slip paper one line. You can also hold down this button to reverse slip paper continuously.

### **RELEASE**

When the printer is in the slip mode (the SLIP light is on or blinking), press this button to release slip paper.

## **Indicator lights**

The control panel lights provide information on printer conditions.

### **Paper roll panel lights**

#### **POWER**

The POWER light is on whenever the printer is on.

#### **ERROR**

This indicates an error in the paper roll section of the printer. See Chapter 3 for information on what to do when this light comes on.

#### **PAPER OUT**

This light indicates either the end or the near end of the paper roll. Install a new paper roll and the printer will continue printing.

## ***Slip panel lights***

### POWER

The POWER light is on when the printer is on.

### ERROR

This indicates an error in the slip section of the printer. See Chapter 3 for information on what to do when this light comes on.

### RELEASE

This light indicates that platen and paper feed roller are released so that slip paper can be inserted.

### SLIP

This light indicates that the printer is in the slip mode.

---

## ***Slip Paper Handling***



### **Notes:**

*Use only slip paper that matches the printer's specifications. See Paper Specifications in Chapter 4.*

*Be sure that the slip is flat, without curls, folds, and wrinkles.*

1. Send appropriate control commands from the computer to print on slip paper.

2. When the SLIP light blinks, insert the slip paper into the slip paper inlet using the right edge of the slip paper inlet as a guide. (Follow steps ① and ② in the illustration.)

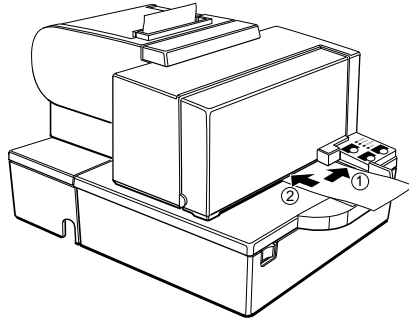

**Note:**

*There is a label on the document table to assist you how to insert slip paper.*

3. Make sure you insert the slip paper into the inlet as far as it will go.
4. When the slip sheet is detected by the sensor, the SLIP light is changed from blinking to on and the paper is automatically drawn into the printer and printing begins.



**Note:**

*After the slip is detected, the printer moves the slip back and forth to detect the position of the top edge of the slip. If the setting position of the slip is not correct, the printer takes a few seconds to detect the position of the top edge of the slip.*

5. After printing when the SLIP light is off, remove the slip.



**Note:**

*An optional front extension table (WT-5000) is available for users who need it to enable handwriting on paper or other uses.*

---

## Using the MICR Reader (Option)

If your printer has the factory installed optional Magnetic Ink Character Recognition (MICR) reader that enables the printer to read and process MICR characters on personal checks, read this section.

### *Reading MICR characters on personal checks*

To use the MICR function with personal checks, follow the steps below:

#### **CAUTION:**

*Do not insert checks with staples in them. This may cause paper jams, MICR reading errors, and damage to the MICR head.*



#### **Note:**

*Be sure that the checks are flat, without curls, folds, or wrinkles.*

1. Wait until the computer sends the **FS a 0** command to the printer, causing it to enter the MICR mode. The SLIP light blinks.

2. Turn the check over so that it is *face down* with the MICR characters on the right-hand side. The MICR characters must be next to the right edge of the paper inlet.

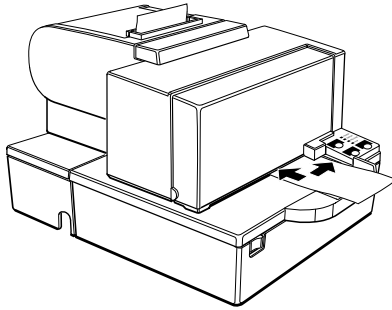

3. Insert the check straight into the paper inlet, using the right edge of the paper inlet as a guide.
4. Insert the check as far as it will go. The printer will detect the check and start drawing it in.
5. When the printer starts drawing it in, let go of the check immediately. The SLIP light quits blinking but stays on.
6. When printing and MICR reading are finished, the printer ejects the check and the SLIP light starts blinking again.
7. Remove the check by pulling it straight up; do not pull it at an angle. The SLIP light goes off.

See Chapter 3 to find out how to clean the MICR mechanism.

# Chapter 3

---

## Troubleshooting

---

---

### Troubleshooting

This chapter gives solutions to some printer problems you may have.

#### General problems

---

##### **The lights on the control panel do not come on.**

---

Make sure that the power supply cables are correctly plugged into the printer, the power unit, and to the power outlet.

Make sure that power is supplied to the power outlet. If the outlet is controlled by a switch or timer, use another outlet.

#### Printing problems

---

##### **The paper roll section ERROR light is on (not blinking) and nothing is printed.**

---

If the PAPER OUT light is **on**, the paper roll is not installed or is at or near the end. Install a new paper roll. See Chapter 1 for instructions.

If the PAPER OUT light is **off**, make sure that the paper roll cover is properly closed. Press the printer cover until the cover audibly clicks into place.

---

##### **An ERROR light is blinking and the printer does not print.**

---

First, turn off the printer and check for a paper jam. (See the paper jam description on page 3-4.)



If there is no paper jam and the printer has been printing for quite a while, the print head may be overheated. If the print head is overheated, the printer will resume printing when the head has cooled (usually within two or three minutes).

If there is no paper jam and the print head is not overheated, turn off the printer and turn it back on after about 10 seconds. If the ERROR light is still flashing, contact a qualified service person.

---

**The ERROR light is off, but nothing is printed.**

---

Try to run the self test to check that the printer works properly. See the self test instructions in Chapter 1 to run the self test. If the self test does not work, contact your dealer or a qualified service person.

If the self test works properly, check the following:

1. Check the connection at both ends of the interface cable between the printer and the computer. Also make sure that this cable meets the specifications for both the printer and the computer.
2. The data transmission settings may be different between the printer and computer. Make sure that the printer's DIP switch settings for data transmission are the same as the computer's. You can print the printer's interface settings using the self test.

If the printer still does not print, contact your dealer or a qualified service person.

---

**The slip section of the printer sounds like it is printing, but nothing is printed.**

---

The ribbon cassette may not be installed properly. See the instructions in Chapter 1.

The ribbon may be worn out. Replace the ribbon cassette as described in Chapter 1.

---

## Paper roll printing is poor.

---

Paper dust on the heating element of the thermal print head can lower the print quality. Try cleaning the print head as described below:

### *Cleaning the paper roll print head*

## **CAUTIONS:**

*After printing, the print head can be very hot. Be careful not to touch it. Also let it cool before you clean it.*

*Do not damage the print head by touching it with your fingers or any hard object.*

1. Open the paper roll cover.
2. Clean the thermal element of the print head with a cotton swab moistened with an alcohol solvent (ethanol, methanol, or IPA).

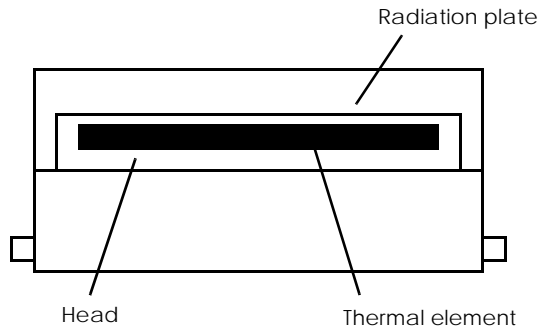

---

## The slip section printout is faint.

---

The ribbon may be worn out. Replace the ribbon cassette as described in Chapter 1.

---

**A line of dots is missing in the printout.**

---

The print head may be damaged. Stop printing and contact your dealer or a qualified service person.

***Paper handling problems***

---

**Paper is jammed inside the printer.**

---

**CAUTIONS:**

*Do not touch the print head because it can be very hot after printing continuously for a long time.*

*Do not move the print head carriage for the slip section.*

To clear a paper jam, follow the steps below:

1. Turn the printer off and open the appropriate printer cover (either front or paper roll).
2. If the paper is jammed in the paper roll section, press the cover open button to open the cover. Then remove the jammed paper and put the roll back in the printer and close the cover.

If the paper is jammed in the slip section, open the front cover and remove the jammed paper.

3. If paper is caught in the automatic cutter in the receipt section and the paper roll cover cannot be opened, open the cutter cover as shown below.

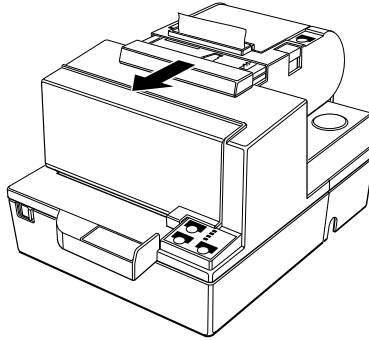

4. Then turn the knob until you see  $\nabla$  in the opening, as shown in the illustration below. This returns the cutter blade to the normal position. Also notice that there is a label near the cutter to assist you.

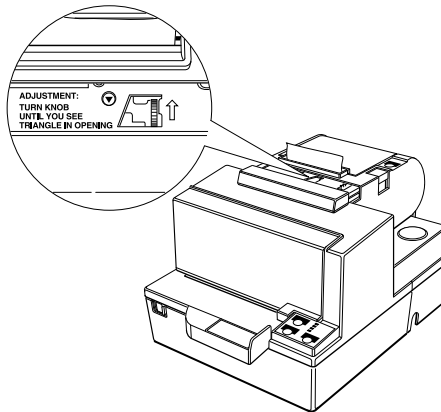

5. Close the cutter cover.
6. Open the paper roll cover.
7. Remove the jammed paper.

## *Auto cutter problems*

---

### **The auto cutter is jammed.**

---

If a foreign object such as a push pin or paper clip drops in the auto cutter and causes the auto cutter to lock up, the printer enters an error state and begins the recovery operation automatically.

If the problem is not serious, the auto cutter returns to its normal position without any intervention by the user.

If the auto cutter does not return to its normal position by itself, follow the steps below to correct the problem:

1. Pull the cutter cover toward you so that you can rotate the cutter motor knob.

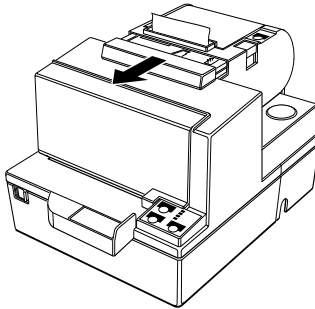

- Following the instructions on the label, rotate the knob until the  appears in the hole.

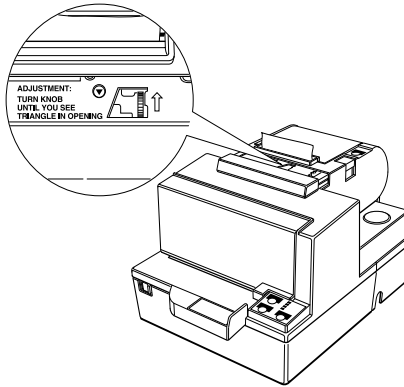

- Close the cutter cover.

---

## ***Cleaning the Optional MICR Mechanism***

### ***MICR cleaning (when the printer is used with a MICR reader)***

Use a moistened cleaning sheet for the MICR head. Use an adhesive cleaning sheet for the MICR feed roller. See the table below for cleaning frequency.

Part to clean	Type of cleaning sheet	Cleaning frequency
MICR head	Moistened cleaning sheet	Every 6000 passes or once a month
MICR feed roller	Adhesive cleaning sheet	Every 6000 passes or once a month



**Note:**

*If you encounter frequent MICR reading errors, use one of the two methods described below.*

## Moistened cleaning sheet

Use the following or an equivalent commercially available cleaning sheet: PRESAT brand (KIC) "CHECK READER CLEANING CARD."

## Adhesive cleaning sheet

A cleaning sheet is available from EPSON.  
Part name: Sheet-roller cleaning-A  
Part number: 1038046

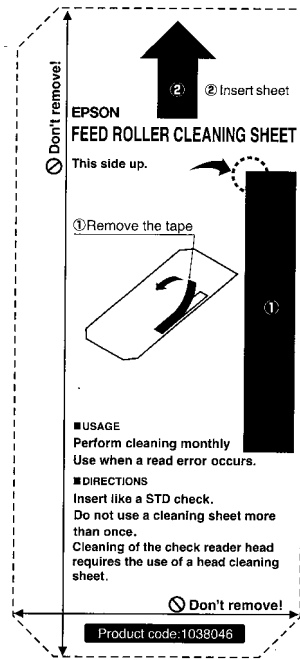

## Cleaning procedure

You can perform cleaning either in self mode or command mode. These modes are described below.

### Self mode

1. Load paper roll into the printer.
2. Turn off the power.
3. Open the front cover.
4. Turn the power back on while holding down the RELEASE button.
5. Press the RELEASE button four times.
6. Close the front cover.
7. The printer prints the following message on receipt paper and the SLIP LED flashes.

\*\*\*\* WAVEFORM TRANSMISSION MODE \*\*\*\*  
Please set check.

8. If you are using the adhesive cleaning sheet, remove the tape, as shown below.

Remove tape here

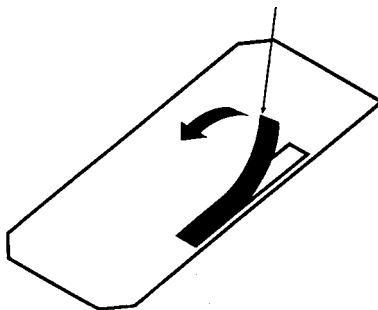

### **CAUTION:**

*Do not remove any other area of the paper besides the tape.*



9. Load the cleaning sheet like a standard check. If you are using the adhesive cleaning sheet, insert the printed (adhesive) side up.

### **CAUTION:**

*Be sure the printed (adhesive) side is up, and the sheet is inserted in the right direction.*

10. When the sheet is ejected, press the RELEASE button, and remove the sheet from the printer.

### **CAUTION:**

*Do not use a cleaning sheet more than once.*

#### *Command mode*

1. Send the FS s cleaning command to the printer.
2. Perform steps 8 to 10, as described in self mode.

---

## **Hexadecimal Dump**

This feature allows experienced users to see exactly what data is coming to the printer. This can be useful in finding software problems. When you turn on the hex dump function, the printer prints all commands and other data in hexadecimal format along with a guide section to help you find specific commands.

To use the hex dump feature, follow these steps:

1. After you make sure that the printer is off, open the cover.
2. Hold down the FEED button while you turn on the printer.
3. Close the cover.

4. Run any software program that sends data to the printer. The printer prints “Hexadecimal Dump” and then all the codes it receives in a two-column format. The first column contains the hexadecimal codes and the second column gives the ASCII characters that correspond to the codes.

```
Hexadecimal Dump
1B 21 00 1B 26 02 40 40 .!.. & . @ @
1B 25 01 1B 63 34 00 1B .%.. c4 ..
41 42 43 44 45 46 47 48 ABCDEFGH
```

- A period (.) is printed for each code that has no ASCII equivalent.
  - During the hex dump all commands except **DLE EOT** and **DLE ENQ** are disabled.
5. Open the cover to set the printer off line so that it will print the last line.
  6. Close the cover and turn off the printer or reset it to turn off the hex dump mode.

## Chapter 4

# Reference Information

---

## Printing Specifications

### Slip Paper

<b>Printing method:</b>	Serial impact dot matrix
<b>Head wire configuration:</b>	9-pin vertical line, 0.353 mm (1/72-inch) wire pitch
<b>Head wire diameter:</b>	0.29 mm (.01")
<b>Printing direction:</b>	Bidirectional, minimum distance printing
<b>Number of characters:</b>	Alphanumeric characters: 95 International characters: 32 Extended graphics: 128 × 10 pages (including space page)
<b>Character structure:</b>	Font A: 9 × 9, 3-dot spacing (in half-dot units) Font B: 7 × 9, 2-dot spacing (in half-dot units)  Larger spacing can be set by using <b>ESC SP</b> .

### Character size and printing speed

Character structure (Horizontal dots × vertical dots)	Character spacing (half dots)	Characters per inch	Characters per second (carriage moving speed)	Characters per line	Character size (width × height)
9 × 9	3 dots	12.5	233	66	1.6 × 3.1 mm (.06" × .12")
7 × 9	2 dots	16.7	311	88	1.3 × 3.1 mm (.05" × .12")

## Receipt Paper

<b>Printing method:</b>	Thermal line printing
<b>Dot density:</b>	180 dpi × 180 dpi [the number of dots per 25.4 mm (1")]
<b>Printing direction:</b>	Unidirectional with friction feed
<b>Printing width:</b>	72 mm (2.83"), 512 dot positions
<b>Characters per line:</b>	42 (Font A) (default) 56 (Font B)
<b>Character spacing:</b>	0.28 mm (.01") (2 dots) (Font A)(default) 0.28 mm (.01") (2 dots) (Font B) Programmable by control command.
<b>Printing speed - High speed mode:</b>	28.4 lines/second maximum (4.23 mm (1/6") feed, at 24V, 28° C, density level 2) 120 mm/second maximum (approximately 4.72"/second) Speeds are switched automatically depending on the voltage applied to the printer and the head temperature of the printer.
<b>Printing speed - Low power consumption mode:</b>	Approximately 16.5 lines/second (4.23 mm (1/6") feed) Approximately 70 mm/second (approximately 2.76"/second)
<b>Printing speed - Ladder bar code printing mode:</b>	Approximately 42 mm/second (approximately 1.7"/second)



### **Note:**

*Printing speed may be slower, depending on the data transmission speed and the combination of control commands.*

**Paper feeding speed:** Approximately 120 mm/second  
(approximately 4.72"/second) continuous feeding

**Line spacing (default):** 4.23 mm (1/6")  
Programmable by control command.

**Number of characters:** Alphanumeric characters: 95  
International characters: 32

Extended graphics: 128 × 7 pages  
(including one space page)

**Character structure:** Font A: 12 × 24 (including 2-dot spacing  
in horizontal)

Font B: 9 × 17 (including 2-dot spacing in  
horizontal)

Font A is the default

### *Character size, characters per line*

	Standard		Double-height		Double-width		Double-width/ Double-height	
	W x H (mm)	CPL	W x H (mm)	CPL	W x H (mm)	CPL	W x H (mm)	CPL
<b>Font A</b> 12 x 24	1.41 x 3.39 (.06" x .13")	42	1.41 x 6.77 (.06" x .27")	42	2.82 x 3.39 (.11" x .13")	21	2.82 x 6.77 (.11" x .27")	21
<b>Font B</b> 9 x 17	0.99 x 2.40 (.04" x .09")	56	0.99 x 4.80 (.04" x .19")	56	1.98 x 2.40 (.08" x .09")	28	1.98 x 4.80 (.08" x .19")	28

\* CPL = Characters Per Line

\* Space between characters is not included

\* Characters can be scaled up to 64 times as large as the standard sizes.

---

## ***Ribbon Specifications***

<b>Type:</b>	Exclusive cassette ribbon
<b>Ribbon cassette specifications:</b>	Part number: ERC-31 (P)
	Color: (P) Purple
	Ribbon life: (P) 7,000,000 characters (when 1 character=18 dots)

---

## ***MICR Reader (Option)***

The MICR reader is a factory-installed option.

<b>Available fonts:</b>	E-13B, CMC7
<b>Reading method:</b>	Magnetic bias
<b>Recognition rating:</b>	98% or more at 25°C (75°F) Rating = $([\text{total checks} - \text{number misread or not identified}] / \text{total checks}) \times 100$ Check paper tested is EPSON standard check paper. Checks must be flat, without curls, folds, or wrinkles. The magnetic bias method is used for reading.
<b>Paper type:</b>	Normal check paper with thickness of 0.09 to 0.36 mm (0.0035 to 0.141") Size: 70 mm × 70 mm to 210 mm × 297 mm (A4) (2.76" × 2.76" to 8.27" × 11.69")

## Paper Specifications

<b>Paper roll (single-ply):</b>	Size:	Width: 79.5 mm $\pm$ 0.5 mm (3.13" $\pm$ 0.02")
	Maximum outside diameter:	83 mm (3.27")
	Paper roll spool diameter:	Inside: 12 mm (0.47") Outside: 18 mm (0.71") Paper must not be pasted to the paper roll spool.
	Take up paper roll width:	80 $\pm$ <sub>1.0</sub> <sup>0.5</sup> mm 3.15" $\pm$ <sub>0.04</sub> <sup>0.02</sup>

<b>Slip paper:</b>	Paper type:	Normal paper; Carbon copy paper; Pressure sensitive paper
	Total thickness:	0.09 to 0.36 mm (.0035 to .0141")
	Size (W $\times$ L):	70 mm $\times$ 70 mm to 210 mm $\times$ 297 mm (A4) (2.76" $\times$ 2.76" to 8.27" $\times$ 11.69")

**Ambient temperature and copy capability** Copy capability is greatly influenced by the ambient temperature, so printing must be performed under the conditions described in the table below.

### *Relationship between ambient temperature and number of copies*

Number of copies	Ambient temperature (print mode)
Original + 4 copies	Approx. 20° to 45°C (68° to 113°F)
Original + 1 to 3 copies	5° to 45°C (41° to 113°F)

**Copy capability and paper thickness:** Normal paper (single-ply): 0.09 to 0.2 mm (.0035 to .0079")

Carbon copy paper combination:  
5 sheets maximum (original + 4 copies) at  
20° to 45°C (68° to 113°F)

Backing paper: 0.06 to 0.15 mm (.0023 to .0059")

Copy and original: 0.04 to 0.07 mm (.0015 to .0028")

Carbon paper: Approximately 0.035 mm (.0014")

Total thickness: 0.30 mm (.0118") or less (for any combination, from a single original to an original + 3 copies)

0.36 mm (.0141") or less (for any combination, from a single original to an original + 4 copies)

Pressure sensitive paper:  
5 sheets maximum (original + 4 copies) at  
20° to 45°C (68° to 113°F)

Backing paper: 0.06 to 0.15 mm (.0023 to .0059")

Copy and original: 0.06 to 0.075 mm (.0023 to .003")

Total thickness: 0.24 mm (.0094") or less (original to original + 3 copies)

0.30 mm (.0118") or less (original + 4 copies)



**Note:**

*When using multi-ply paper that consists of an original and three or four copies, be sure to print with a 9 × 9 font. If a 7 × 9 font is used, some characters on some of the copies may not be readable.*



## Notes on slip paper

- ❑ The slip paper must be flat, without curls or wrinkles, especially at the top edges. Otherwise, the paper may rub against the ribbon and become dirty.
- ❑ There must be no glue on the bottom edge. Choose slip paper carefully since paper feeding and insertion are affected by gluing conditions (such as glue quality, method, and length) and glue location (see the illustration below). Be especially careful when slip paper is wide and has glue on the left edge, since it may not feed in a straight line.

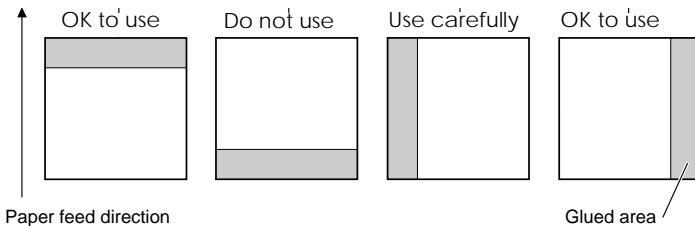

- ❑ Since the BOF sensor uses a photo detector, do not use paper that has holes at the detector position, or is translucent.

- ❑ Since the TOF sensor uses a reflective photo sensor and it detects from the back of slip paper, do not use paper that has holes or dark portions with low reflection (less than 40% reflection) at the sensor position.

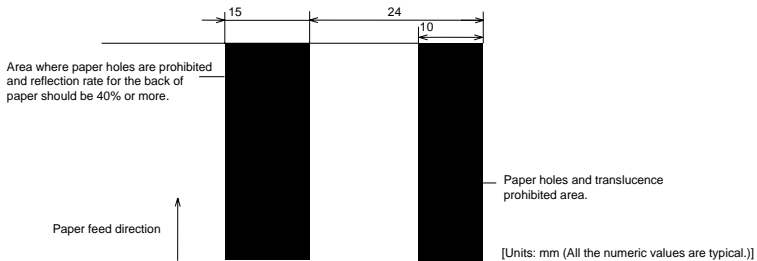
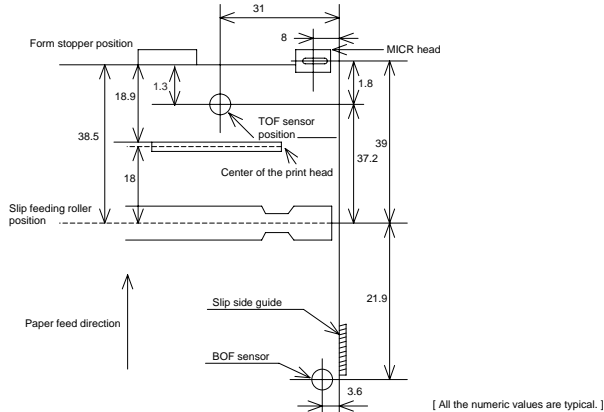

- ❑ Use thinner paper (N30 or equivalent) between the top and bottom sheets of multi-ply paper. If thick paper is used, the copy capability is lowered.

---

## Electrical Characteristics

<b>Supply voltage:</b>	+24 VDC $\pm$ 10% (optional power supply: EPSON PS-170)	
	Ripple voltage: 300mVpp or less (only when the printer is used with the MICR reader).	
<b>Current consumption:</b> (at 24V, except for drawer kick-out driving)	<input type="checkbox"/> Operating: Slip	Mean: approximately 1.9A (character font A $\alpha$ -N all columns printing) Peak: approximately 8.0A (20 msec) When the print platen is released: 2.0A (200 msec)
	<input type="checkbox"/> Operating: Receipt	Mean: approximately 1.7A (character font A $\alpha$ -N all columns printing) Peak: Approximately 7.7A
	Low power consumption mode:(only for receipt)	Mean: approximately 1.2A (character font A $\alpha$ -N all columns printing) Peak: Approximately 6.2A
	Standby:	Mean: approximately 0.3A

---

## *Reliability*

<b>Slip:</b>	Life (when printing alphanumeric characters):	Mechanism:	12,000,000 lines
		Print head:	200 million characters (when printing with font B)
		MICR reader mechanism (only when the printer is used with the MICR reader): End of life is defined to have reached the end of its life when it reaches the beginning of the Wearout Period.	240,000 passes
	MTBF:	180,000 hours Failure is defined as Random Failure occurring at the time of the Random Failure Period.	
	MCBF:	29,000,000 lines This is an average failure interval based on failures relating to wearout and random failures up to the life of 12 million lines.	

<b>Receipt:</b>	<b>Life:</b>	<b>Mechanism:</b>	15,000,000 lines
		<b>Thermal head:</b>	100 million pulses, 100 km
		<b>Auto cutter:</b>	1,500,000 cuts
	<b>MTBF:</b>		180,000 hours
	<b>MCBF:</b>		37,000,000 lines

---

### *Environmental Conditions*

<b>Temperature:</b>	<b>Operating:</b>	5° to 45°C (41° to 113°F)
	<b>Storage:</b>	-10° to 50°C (14° to 122°F) (except for paper)
<b>Humidity:</b>	<b>Operating:</b>	10 to 90% RH
	<b>Storage:</b>	10 to 90% RH (except for paper)

## Appendix A

---

# Dip Switch and Paper Near End Settings

Although the factory settings are best for almost all uses, if you have special requirements, you can change the DIP switch or paper near end settings.

---

### Setting the DIP Switches

#### DIP switch functions

Your printer has two sets of DIP switches. The functions of the switches are shown in the following tables.

#### Serial interface specification

##### Set 1

SW	Function	ON	OFF
1-1	Data receive error	Ignored	Prints "?"
1-2	Receive buffer capacity	45 bytes	4K bytes
1-3	Handshaking	XON/XOFF	DTR/DSR
1-4	Data word length	7 bits	8 bits
1-5	Parity check	Enabled	Disabled
1-6	Parity selection	Even	Odd
1-7	Transmission speed (See the table below)		
1-8			

### Transmission Speed

Transmission Speed (BPS)-bits per second	1-7	1-8
2400	ON	ON
4800	OFF	ON
9600	ON	OFF
19200	OFF	OFF

### Set 2

SW	Function	ON	OFF
2-1	Handshaking (BUSY condition)	Receive buffer full	Off line or receive buffer full
2-2	Customer display (DM-D) connection	Connected	Not connected
2-3	Selects print density	Refer to table below	
2-4			
2-5	Reserved: do not change settings Fixed to OFF		
2-6			
2-7	I/F pin 6 reset signal	Enabled	Disabled
2-8	I/F pin 25 reset signal	Enabled	Disabled

### Print Density and Low Power consumption mode selection (Only for Receipt)

Print Density	SW 2-3	SW 2-4
Low power consumption mode	ON	ON
1 (Light)	OFF	OFF
2 	ON	OFF
3 (Dark)	OFF	ON

**Notes:**

- When pin 6 of the interface connector is used for the reset signal, the printer is reset at MARK on the RS-232 level.
- When pin 25 of the interface connector is used for the reset signal, the printer is reset at SPACE on the RS-232 level or at HIGH on the TTL level.
- Changes in DIP switch settings (excluding switches 2-7 and 2-8 interface reset signals) are recognized only when the printer power is turned on or when the printer is reset by using the interface. If the DIP switch setting is changed after the printer power is turned on, the change does not take effect until the printer is turned on again or is reset.
- If you turn on DIP switch 2-7 or 2-8 while the printer is turned on, the printer may be reset, depending on the signal state. DIP switches should not be changed while the printer power is on.
- If the print density is set to level 3 or 4, the printing will be at the low speed.
- In a low power consumption, printing speed is fixed to 70 mm/sec.



## Parallel interface specification

### Set 1

SW	Function	ON	OFF
1-1	Auto line feed	Always enabled	Always disabled
1-2	Receive buffer capacity	45 bytes	4K bytes
1-3 ~ 1-8	Undefined	—	—

### Set 2

SW	Function	ON	OFF
2-1	Handshaking (BUSY condition)	<ul style="list-style-type: none"><li>•Receive buffer full</li><li>•Reading data</li></ul>	<ul style="list-style-type: none"><li>•Off-line</li><li>•Receive buffer full</li><li>•Reading data</li></ul>
2-2	Reserved (Do not change settings)	Fixed to Off	
2-3 2-4	Selects print density	Refer to table below	
2-5 ~ 2-7	Reserved (Do not change settings)	Fixed to Off	
2-8	I/F pin 31 reset signal (Do not change settings)	Fixed to On	

*Print Density and Low power consumption mode selection (Only for Receipt)*

<b>Print Density</b>	<b>SW 2-3</b>	<b>SW 2-4</b>
Low power consumption mode	ON	ON
1 (Light)	OFF	OFF
2 	ON	OFF
3 (Dark)	OFF	ON

**Notes:**

- When pin 6 of the interface connector is used for the reset signal, the printer is reset at MARK on the RS-232 level.
- When pin 25 of the interface connector is used for the reset signal, the printer is reset at SPACE on the RS-232 level or at HIGH on the TTL level.
- Changes in DIP switch settings (excluding switch 2-8 interface reset signal) are recognized only when the printer power is turned on or when the printer is reset by using the interface. If the DIP switch setting is changed after the printer power is turned on, the change does not take effect until the printer is turned on again or is reset.
- If you turn on DIP switch 2-8 while the printer is turned on, the printer may be reset, depending on the signal state. DIP switches should not be changed while the printer power is on.
- If the print density is set to level 3 or 4, the printing will be at the low speed.
- In a low power consumption, printing speed is fixed to 70 mm/sec.

## Changing the DIP switch settings

If you need to change settings, follow the steps below to make your changes:

### **CAUTION:**

*Turn off the printer while removing the DIP switch cover to prevent an electric short, which can damage the printer.*

1. Make sure the printer is turned off.
2. Remove the screw from the DIP switch cover. Then take off the DIP switch cover, as shown in the illustration below.

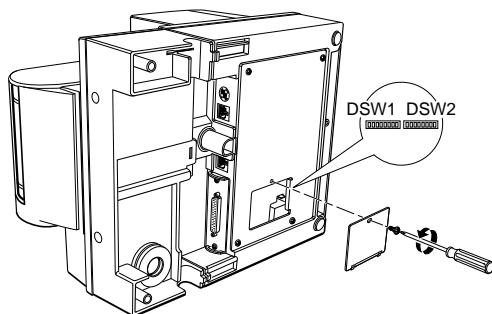

3. Set the switches using a pointed tool, such as tweezers or a small screwdriver.
4. Replace the DIP switch cover. Then secure it with the screw.

The new settings take effect when you turn on the printer.

---

## Adjusting the Paper Near End Sensor

The paper near end sensor detects when paper is almost gone by measuring the diameter of the paper roll. The sensor has two settings.

Because of variations in paper roll cores, it is not possible for the sensor to measure exactly the length of paper left on the roll when the sensor is triggered. Of the two settings, the factory setting (lower) leaves the least amount of paper on the roll when the sensor is triggered. If you want more paper left, change the setting as described below.



**Note:**

*The factory setting is based on a paper roll core with an outside diameter of 18mm and an inside diameter of 12mm. If you use a paper roll with a core with an outside diameter of more than 18mm, it is better to change to the upper setting, as described below.*

1. Open the paper roll cover, and remove the paper roll.
2. Loosen the adjusting screw and move the tab up to the upper setting.

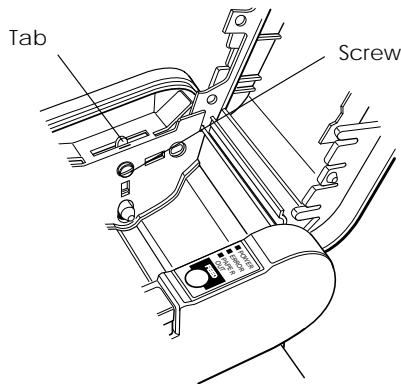

3. Tighten the adjusting screw, and check to be sure that the detecting lever moves freely.
4. Replace the paper roll.

## Appendix B

### **EPSON Sales Subsidiaries**

---

EPSON AMERICA INC./OEM DIV.	20770 Madrona Ave. Torrance, CA 90559-2842 U.S.A. Tel : 1-310-787-6300 Fax : 1-310-782-5350
EPSON EUROPE B.V.	Prof. J.H. Bavincklaan 5 1183 AT Amstelveen The Netherlands Tel : 31-(0)20-5475-251 Fax : 31-(0)20-6454-315
EPSON Deutschland GmbH	Zülpicher Strasse 6, 40549 Düsseldorf 11, Germany Tel : 49-(0)211-5603152 Fax : 49-(0)211-5603319
EPSON U.K. LIMITED	Campus 100 Maylands Ave. Hemel Hempstead Herts. HP2 7TJ United Kingdom Tel : 44-1(0)442-61144 Fax : 44-1-(0)442-227-244
EPSON FRANCE S.A.	68 Bis Rue Marjolin B.P. 320 92305 Levallois Perret Cedex, France Tel : 33-(0)1-40-87-38-62 Fax : 33-(0)1-47-37-15-10
EPSON IBERICA, S.A.	Avda. de Roma, 18-26 08290 Cerdanyola del Vallès (Barcelona), Spain Tel : 34-(9)3-582-2500 Fax : 34-(9)(3-582-1555
EPSON ITALIA S.P.A.	V.le F Ili Casiraghi, 427 20099 Sesto Si Giovanni (Milan), Italy Tel : (39)226-2331 Fax (39)2244-0750
EPSON SINGAPORE PTE. LTD.	No. 1 Raffles Place #26-00 OUB Centre Singapore, 0104 Tel : 5-530477 Fax : 5-5338119

EPSON HONG KONG LIMITED	25/F., Harbor Centre, 25, Harbor Road, Wanchai, Hong Kong Tel : 852-2-585-4663 Fax : 852-2-827-4346
EPSON TAIWAN TECHNOLOGY & TRADING LTD.	10f, No. 287, Nanking E. Road, Sec. 3 Taipei, Taiwan R.O.C. Tel : 886-(0)2-717-7360 Fax : 886-(0)2-718-9366
SEIKO EPSON CORP. KOREA OFFICE	10F, KIL 63 Building 60, Yoido Dong, Youngedungpo-Ku, Seoul, Korea Tel : 82-(0)2-784-6027 Fax : 82-(0)2-769-1049
EPSON AUSTRALIA PTY. LTD.	70 Gibbes Street, Chatswood NSW 2067 Australia Tel : 61-(0)2-415-9000 Fax : 61-(0)2-417-0077
EPSON HANBAI CO., LTD. TOKYO OFFICE:	3F Building Kawaguchi Fuda Chofu-Shi Tokyo 182 Japan Tel : 0424-99-7829 Fax : 0424-99-7834
OSAKA OFFICE:	13F Shin-Osaka Daiichi-Seimei Bldg. 5-24 3-Chome Miyahara Yodogawa-ku Osaka 532 Japan Tel : 06-350-4964 Fax : 06-350-4968